

NovaDrain Shallow Installation Guide

1.

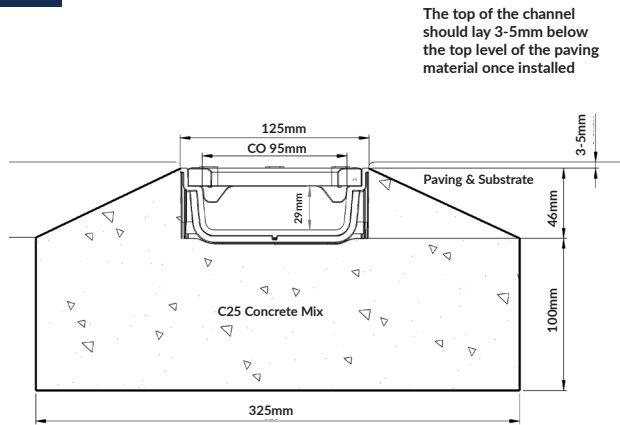

The top of the channel should lay 3-5mm below the top level of the paving material once installed

Trench Preparation

Excavate a trench along the full length of the proposed drainage channel route, ensuring it matches the dimensions specified in Fig. 1. The trench depth must be sufficient to allow effective water runoff into the channel. When installed, the top of the channel should sit approximately 3-5 mm below the finished surface level (e.g. paving). Consider appropriate drain route and build in any further pipework accordingly.

Important: When excavating the trench, it is necessary that the correct fall is integrated into the run.

2.

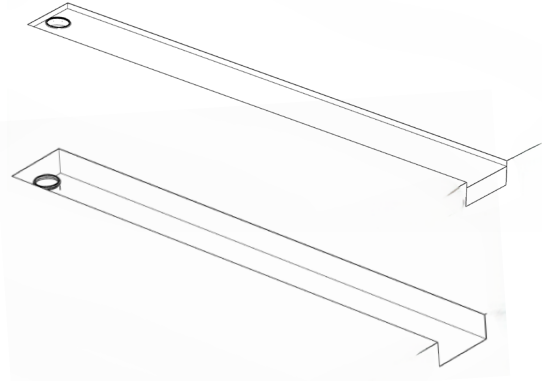

Base Preparation

Place a 100 mm layer of semi-dry concrete into the base of the trench. The concrete must have a minimum strength of C25 (general purpose mix). Ensure the channel is positioned so that, once installed, its top edge remains 3-5 mm below the finished surface level.

3.

Fig. a

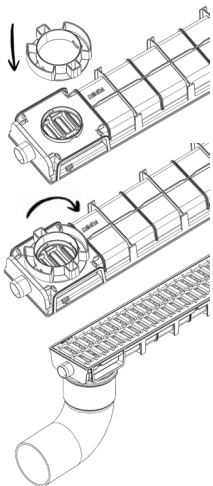
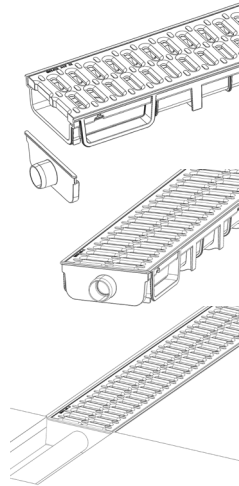

Fig. b



Outlet Connection

Attach the appropriate drainage outlet or adaptor as required:

Fig. a - 110 mm Soil Pipe Adaptor

Carefully cut or break out the round opening to the bottom of the channel (a 64mm holesaw may also be used). Insert the adaptor and secure it using a push-and-twist action.

Fig. b - 32 mm Pipe Outlet (Female End Cap)

The 32 mm outlet is integrated into the female end cap. Carefully cut or break open the outlet hole (a 25mm holesaw may also be used), then fit the end cap into position on the channel.

4.

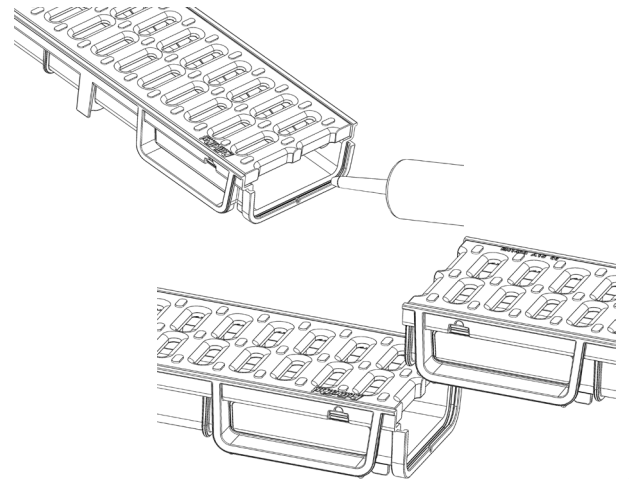

Joints

Joints between channels should be sealed with a suitable sealant.

5.

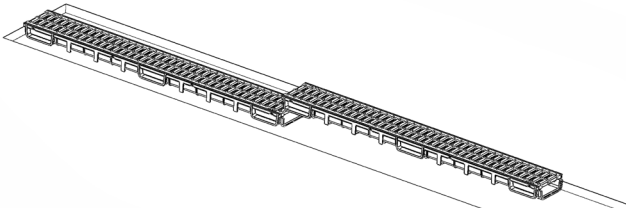

Laying Channels

Align the chosen drainage outlet/adaptor to connect to drain and slot into place, bedding the channel down into the concrete base. Lay the adjacent channels, bedding down as you go.

6.

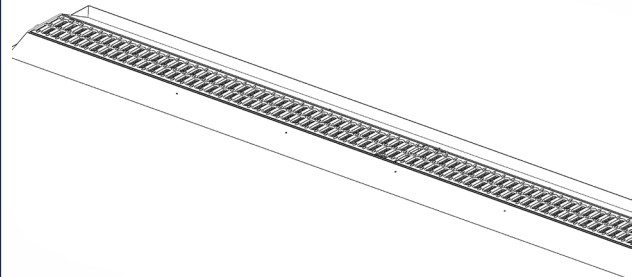

Concrete Channel Support

Once bedded, haunch the channels in place with concrete to fully support the side walls of the channel.

7.

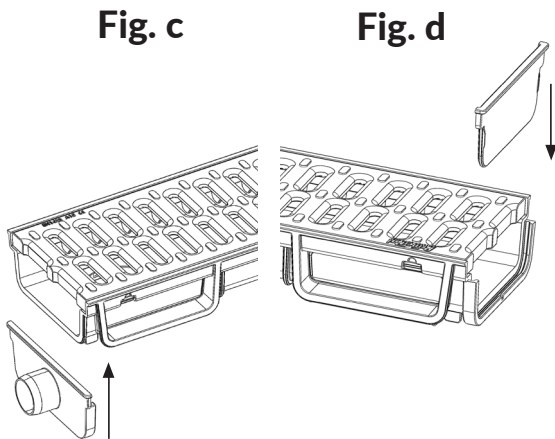

End Cap Fitment

Two types of end caps are available:

Female End Cap / Outlet – Features a recessed slot to accept the channel edge and incorporates a 32 mm outlet collar. Push-fitted from the underside of the channel (see Fig. c) can locate in 7 different positions.

Male End Cap – Designed to slot into the recessed end of the channel and is fitted from the top (see Fig. d).

Ensure all end caps are securely fitted and sealed to prevent leakage and maintain correct water flow.

8.

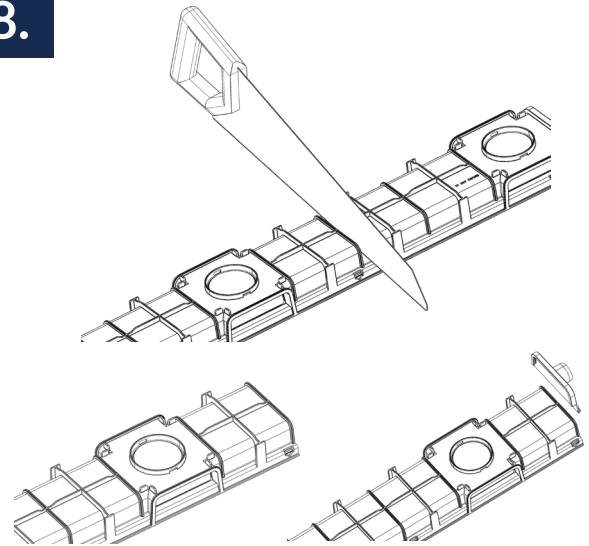

Cutting

The channel can be easily cut to length at designated points along its body. Pre-formed cutting guides are located at regular intervals on the underside.

Cutting at these marked points ensures compatibility is maintained for connecting additional channels or fitting female end caps.

9.

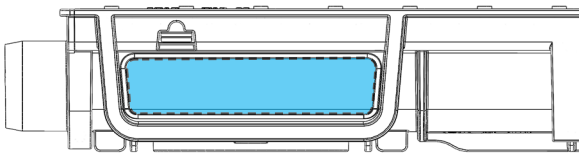

'C' Shape

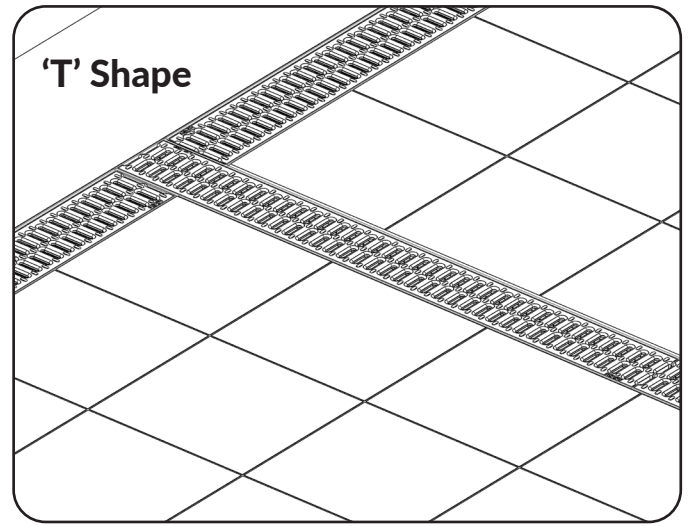

'T' Shape

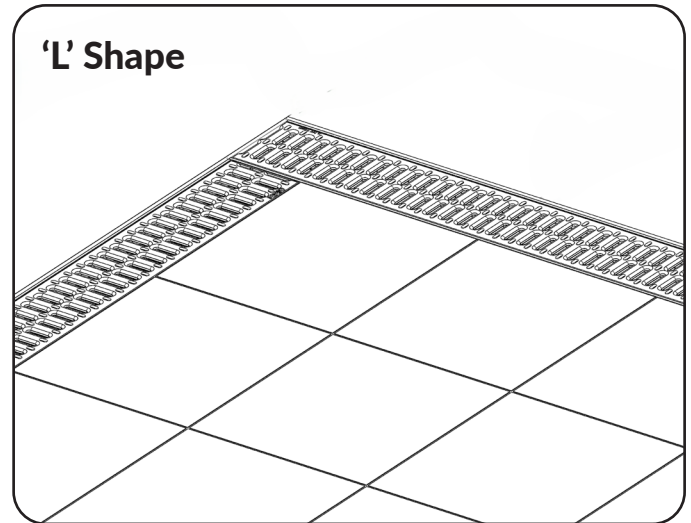

'L' Shape

Corners & Junctions

Remove the required outlet by carefully cutting or breaking along the pre-formed indented score lines.

For changes in direction at corners, ensure water flow is properly managed by fitting end caps to seal open ended channel ends. This helps contain and direct water within the system.

Various changes in direction (L,T & C shapes) can be achieved without the need for additional junction boxes.

For complete perimeter loops, channel sections should be staggered to ensure proper alignment.

Simple T-junctions and corners can be formed by branching from the channel outlet connections.

